

 NIAGARA®



**BARRON™**

**1.0 GPF Pressure Assist Toilet** Elongated ADA Rear Outlet Bowl



# BARRON™

## 1.0 GPF BACK OUTLET TOILET

Elongated ADA Bowl

### FEATURES & SPECIFICATIONS

- Powerful pressure assist flush technology
- Upgraded brass bolt set
- Chrome left and right handle options
- MaP Score 1000g
- Extra large water spot for a clean bowl
- Fully glazed trapway for easy waste removal
- Back Outlet

### CERTIFICATIONS



**Materials:** Vitreous China **Finish Color:** White

#### Codes/Standards:

ASME A112.19.2/CSA B45.1

DOE - Energy Policy Act 1992

California Energy Commission (CEC)

CALGreen Compliant

### MEASUREMENTS

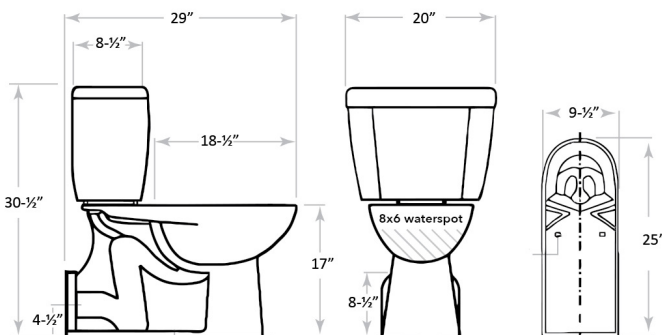

### BULK PACKAGING

**C44.390.01** Left Combo

**C44.391.01** Right Combo

**44.0205.01** Elongated Bowl

UPC Code 732291442053

Packaging Type Kraft Corrugated

Packaging Dimensions 15" W  
18.8" H  
29.7" D

Packaging Weight TBD

Skid Quantity 12 or 18

**44.0301.01LWH** Tank (Left)

**44.0301.01RWH** Tank (Right)

UPC Code Left 732291443050

UPC Code Right 732291443043

Packaging Type Kraft Corrugated

Packaging Dimensions TBD  
TBD  
TBD

Packaging Weight TBD

Skid Quantity 30

\*\*LIMITED LIFETIME WARRANTY on vitreous china products. Toilet tank trim: fill valve and flush valve assembly and plumbing fittings are warranted for a period of fifteen (15) years to the purchaser from the date of purchase. Call Niagara for complete warranty details.